

深圳市亿显国际科技有限公司 ShenZhen Yes-Display International Technology CO.,LTD.			6.0 寸液晶显示屏 6.0 Inch LCD Display Screen	
File NO.		REV	A/01	http://www.yes-display.com

SPECIFICATION FOR

Module:YS-T060001DC01 V1.0

Designed by	R&D Checked by	Quality Department by	Approved by

Approval by Customer:

OK

NG, Problem survey

Approved By _____

Contents

List	Description	Page No.
	Cover	1
	Revision Record	2
	Contents	3
1	Technical parameters	4
2	Block Dimension	5
3	Outline Dimensions	6
4	Input terminal Pin Assignment Description	7
5	LCD Optical Characteristics	9
6	TFT Electrical Characteristics	12
7	Timing Characteristics	14
8	Inspection Standard	15
9	Reliability Test Conditions and Methods	20
10	Cautions and Handling Precautions	22
11	Packing Method	25

深圳市亿显国际科技有限公司 ShenZhen Yes-Display International Technology CO.,LTD.			6.0 寸液晶显示屏 6.0 Inch LCD Display Screen	
File NO.		REV	A/01	http://www.yes-display.com

1. Technical parameters

1.1 LCM General Information

ITEM	STANDARD VALUES	UNITS
LCD type	6.0" TFT	--
Dot arrangement	720(RGB)×1440	dots
Color filter array	RGB vertical stripe	--
Display mode	IPS/ Transmission / Normally White	-
Eyes Viewing Direction	80/80/80/80	--
Driver IC	ST7703	--
Module size	70.24(W)×142.23(H)×1.56(T)(Exclude FPC)	mm
Active area	68.04(W)×136.08(H)	mm
Interface	MIPI4	--
Operating temperature	-20 ~ +70	°C
Storage temperature	-30 ~ +80	°C
Back Light	White LED*16	--

1.2 CTP General Information

CTP type	6.0"	--
Outline Dimension	79.64(W)×156.48(H)X1.1(T)	mm
Touch area	68.54X136.58	mm
Max Number of Fingers	5 point	--
Driver IC	GT1151QM	--
surface hardness	6H	--
Operating temperature	-20 ~ +70	°C
Storage temperature	-30 ~ +80	°C

深圳市亿显国际科技有限公司 ShenZhen Yes-Display International Technology CO.,LTD.			6.0 寸液晶显示屏 6.0 Inch LCD Display Screen	
File NO.		REV	A/01	http://www.yes-display.com

2. Block Dimension

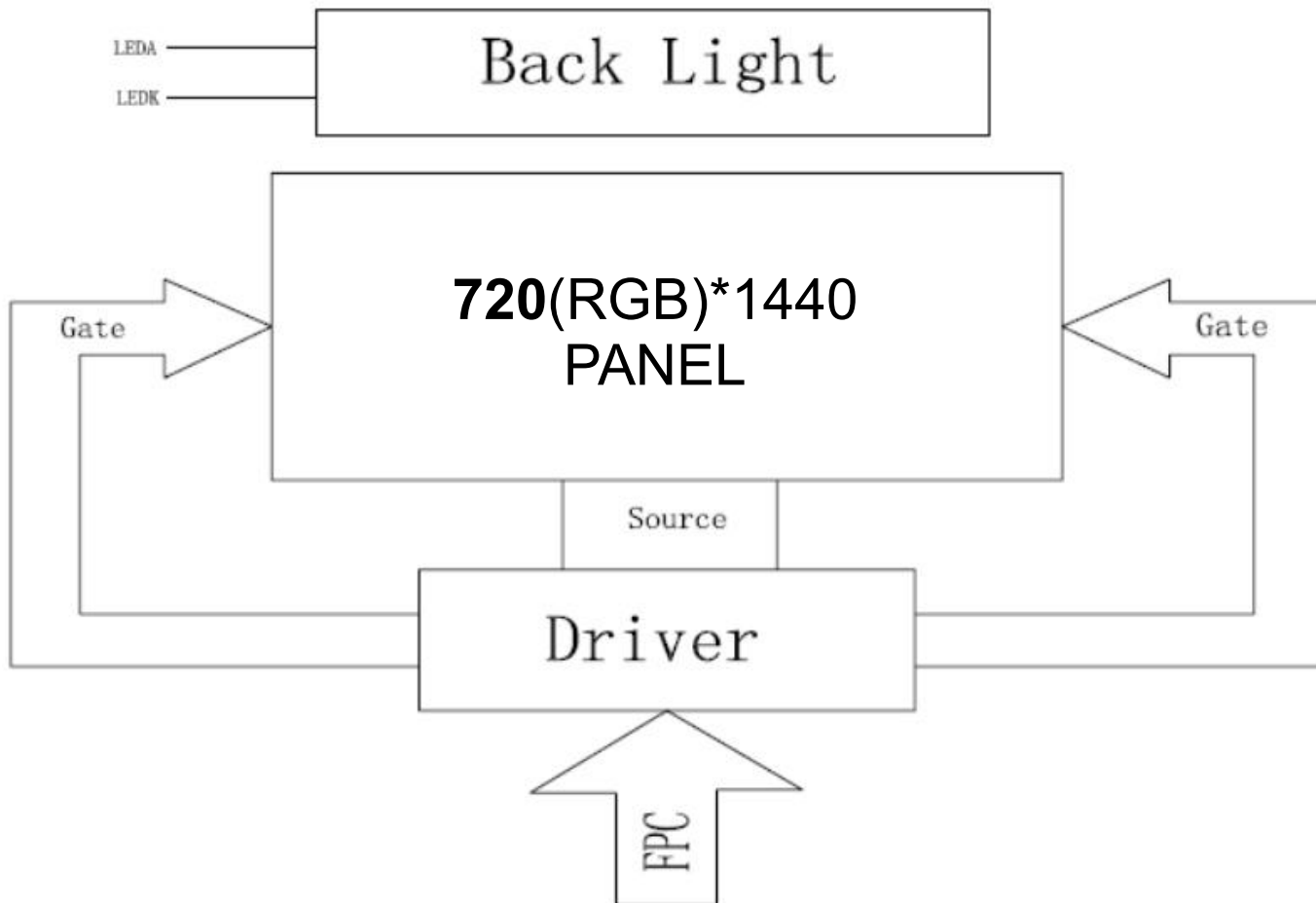

4. Input terminal Pin Assignment Description

4.1 TFT Pin Description

PIN NO.	PIN NAME	DESCRIPTION
1-2	LEDK	Power supply for backlight cathode input terminal.
3-4	LEDA	Power supply for backlight anode input terminal.
5	VCC-3.3V	3.3V VCC power input
6	VCC-1.8V	1.8V VCC power input
7	LCD-RST	Reset signal input terminal, active at 'L'.
8	DSI-TE	TE Single
9	LCD-ID	LCD-ID slection, connect to ground by FPC
10	TP-RST	TP Reset signal input terminal, active at 'L'.
11	TP-INT	TP External interrupt to the host
12	TP-SDA	TP I2C data input and output
13	TP-SCL	TP I2C clock input
14	TPIO-VDD3.3V	TP power 3.3V VCC power input
15	TP-VDD3.3V	TP power 3.3V VCC power input
16	TDP2	DATA2+ differential data signals.
17	TDN2	DATA2- differential data signals.
18	GND	Ground for logic.
19	TDP1	DATA1+ differential data signals.
20	TDN1	DATA1- differential data signals.
21	GND	Ground for logic.
22	TDP3	DATA3+ differential data signals.
23	TDN3	DATA3- differential data signals.
24	GND	System power ground.
25	TDP0	DATA0+ differential data signals.
26	TDN0	DATA0- differential data signals.
27	GND	Ground for logic.
28	TCP	CLK+ differential clock signals

深圳市亿显国际科技有限公司 ShenZhen Yes-Display International Technology CO.,LTD.			6.0 寸液晶显示屏 6.0 Inch LCD Display Screen	
File NO.		REV	A/01	http://www.yes-display.com

29	TCN	CLK- differential clock signals.
30	GND	Ground for logic.
31	GND	Ground for logic.

5. LCD Optical Characteristics

Item	Symbol	Condition	Min.	Typ.	Max.	Unit	Note	
Transmittance (with Polarizer)	T (%)	Θ=0 Normal viewing angle	3.08	3.5	—	%	Measuring with Polarizer , Reference Only	
Transmittance (without Polarizer)	T (%)		10.38	11.8	—	%		
Contrast Ratio	CR		800	1000	—	—	(1)(2)	
Response Time	Rising		T _R	—	10	15	msec	(1)(3)
	Falling		T _F	—	20	25		
Color Gamut	(%)			65	68	—	%	C-light
Color Chromaticity (CIE1931)	White	W _x	(0.283)	(0.303)	(0.323)	—	(1)(4) CF glass C-light	
		W _y	(0.303)	(0.323)	(0.343)			
	Red	R _x	TBD	TBD	TBD	—		
		R _y	TBD	TBD	TBD			
	Green	G _x	TBD	TBD	TBD	—		
		G _y	TBD	TBD	TBD			
	Blue	B _x	TBD	TBD	TBD	—		
		B _y	TBD	TBD	TBD			
Viewing Angle	Hor.	Θ _L	—	80	—	—	(1)(4) Measuring with Polarizer , Reference Only	
		Θ _R	—	80	—			
	Ver.	Θ _U	—	80	—			
		Θ _D	—	80	—			
Optima View Direction	Free						(5)	

Measuring Condition

- Measuring surrounding : dark room
- Ambient temperature : $25\pm 2^{\circ}\text{C}$
- 15min. warm-up time.

Measuring Equipment

- FPM520 of Westar Display technologies, INC., which utilized SR-3 for Chromaticity and BM-5A for other optical characteristics.

Note (1) Definition of Viewing Angle:

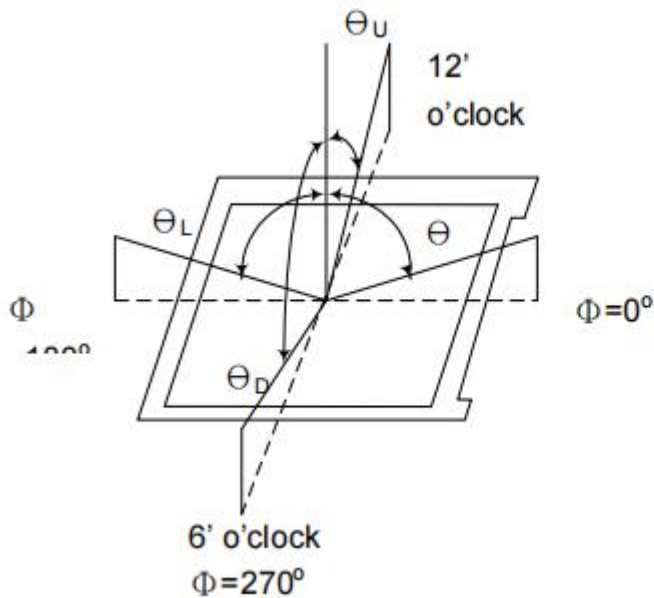

Note (2) Definition of Contrast Ratio (CR) :
measured at the center point of panel

$$\text{CR} = \frac{\text{Luminance with all pixels white}}{\text{Luminance with all pixels black}}$$

Note (3) Definition of Response Time : Sum of T_R and T_F

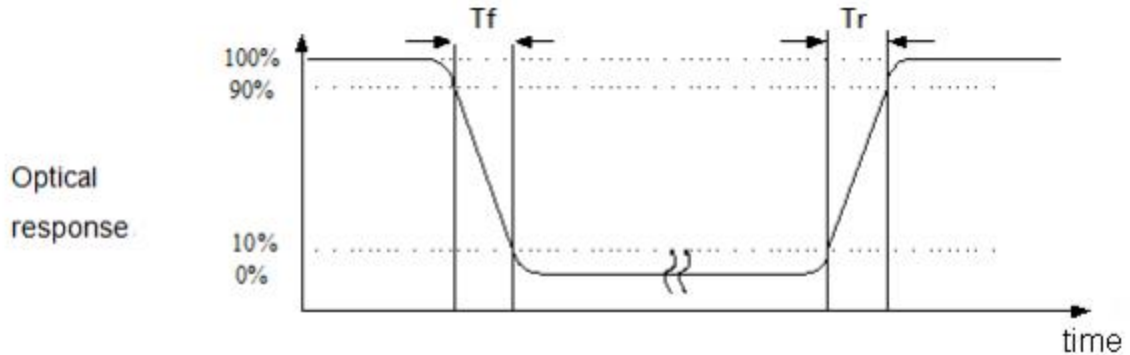

Note (4) Definition of optical measurement setup

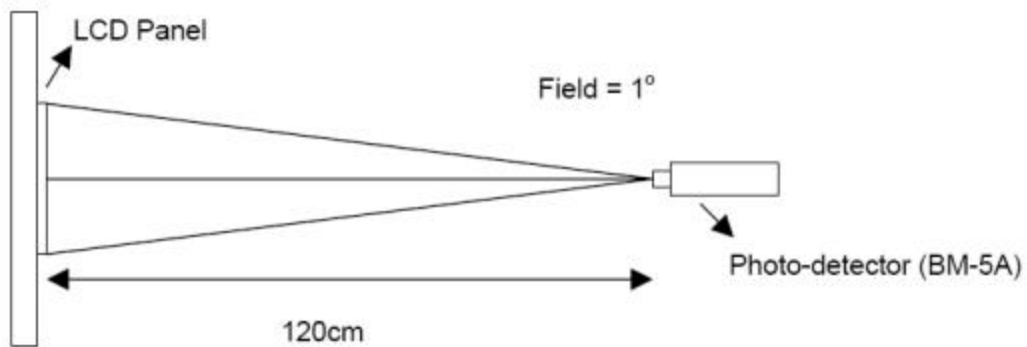

Note (5) Rubbing Direction (The different Rubbing Direction will cause the different optima view direction.)

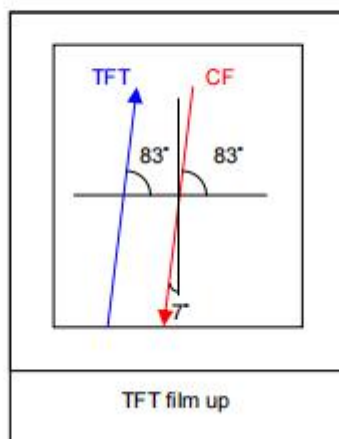

深圳市亿显国际科技有限公司 ShenZhen Yes-Display International Technology CO.,LTD.			6.0 寸液晶显示屏 6.0 Inch LCD Display Screen	
File NO.		REV	A/01	http://www.yes-display.com

6. TFT Electrical Characteristics

6.1 Absolute Maximum Ratings

Item	Symbol	Min.	Max.	Unit
Logic Supply Voltage	VDD	-0.3	4.0	V
Input Voltage	Vin	-0.3	VDD+0.3	V
Operating Temperature	TOP	-20	70	°C
Storage Temperature	TST	-30	80	°C
Storage Humidity	HD	20	90	%RH

6.2 DC Characteristics

Item	Symbol	Min.	Typ.	Max.	Unit	Remark
Logic Supply Voltage	VDD	2.5	2.8	3.6	V	-
Input High Voltage	V _{IH}	0.7VDD	-	VDD	V	-
Input Low Voltage	V _{IL}	GND	-	0.3 VDD	V	-
Output High Voltage	V _{OH}	0.8 VDD	-	VDD	V	-
Output Low Voltage	V _{OL}	GND	-	0.2 VDD	V	-
I/O Leak Current	I _{LI}	-1	-	1	uA	-
Supply Current	IDD	-	TBD	-	mA	-

6.3 LED Backlight Characteristics

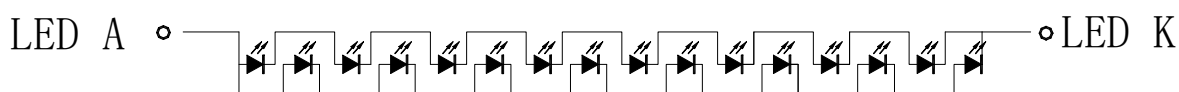

$$V_f = 24.8 \pm 2.4V$$

$$I_f = 20mA/LED * 2 = 40mA$$

Item	Symbol	MIN	TYP	MAX	UNIT	Test Condition
Supply Voltage	V _f	-	24.8	-	V	I _f =40mA
Supply Current	I _f	-	40	-	mA	-
Luminous Intensity for LCM	-	200	240	-	cd/m ²	I _f =40mA
Uniformity for LCM	-	-	60	-	%	I _f =40mA

深圳市亿显国际科技有限公司 ShenZhen Yes-Display International Technology CO.,LTD.			6.0 寸液晶显示屏 6.0 Inch LCD Display Screen		
File NO.		REV	A/01	http://www.yes-display.com	

Life Time	-	-	50000	-	Hr	If=40mA
Backlight Color	White					

7. Timing Characteristics

7.1 TFT Timing Characteristics

7.1.1 Display MIPI Interface Timing Characteristics

The principle flow chart of the different clock lanes power modes is illustrated below.

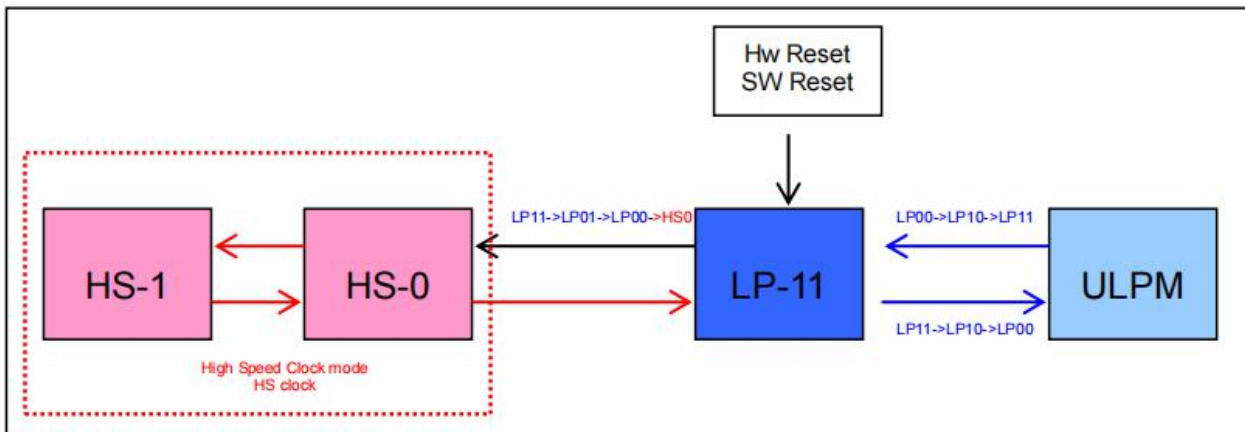

LK+/- lanes can be driven to the Low Power Mode (LPM), when DSI-CLK lanes are entering LP-11:

1. After SW Reset, HW Reset or Power On Sequence =>LP-11
2. After DSI-CLK+/- lanes are leaving Ultra Low Power Mode (ULPM, LP-00) =>LP-10 =>LP-11 (LPM). This sequence is illustrated below.

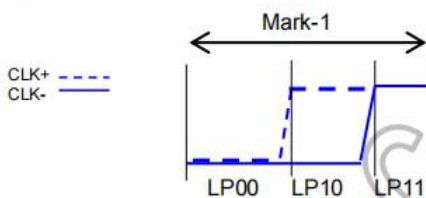

Figure 5.7: From ULPM to LPM

3. After DSI-CLK+/- lanes are leaving High Speed Clock Mode (HSCM, HS-0 or HS-1 State Code) =>HS-0 =>LP-11 (LPM). This sequence and all three mode changes are illustrated below.

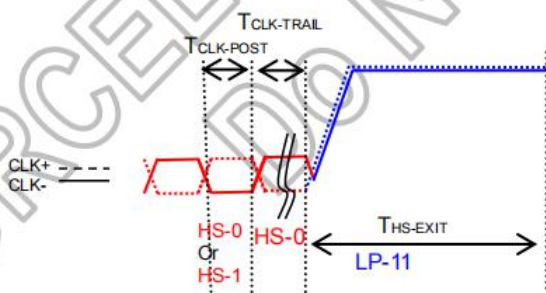

Figure 5.8: From High Speed Clock mode to LPM

Ultra Low Power Mode (LP-00: ULPM)

DSI-CLK+/- lanes can be driven to the Ultra Low power Mode (ULPM), when DSI-CLK lanes are entering LP-00 State. The entering way is from the Low Power Mode (LPM, LP-11 State) =>LP-10 =>LP-00 (ULPM). This sequence is illustrated below.

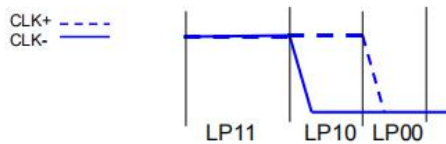

Figure 5.9: From LPM mode to ULPM

High Speed Clock Mode (HSCM)

DSI-CLK+/- lanes can be driven to the High Speed Clock Mode (HSCM), when DSI-CLK lanes are starting to work between HS-0 and HS-1 State. The entering way is from the Low Power Mode (LPM, LP-11 State) =>LP-01 =>LP-00 =>HS-0 =>HS-0/1 (HSCM). This sequence is illustrated below.

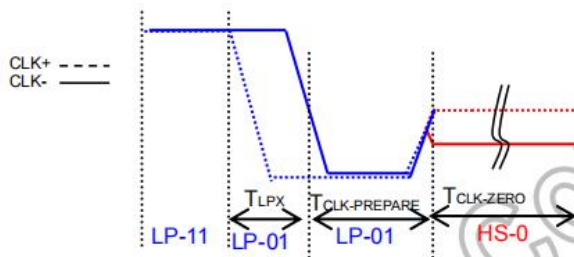

Figure 5.10: From LPM mode to HSCM

High Speed Clock Burst

The high speed clock (DSI-CLK+/-) is started before high speed data is sent via DSI-Dn+/- lanes. The high speed clock continues clocking after the high speed data sending has been stopped.

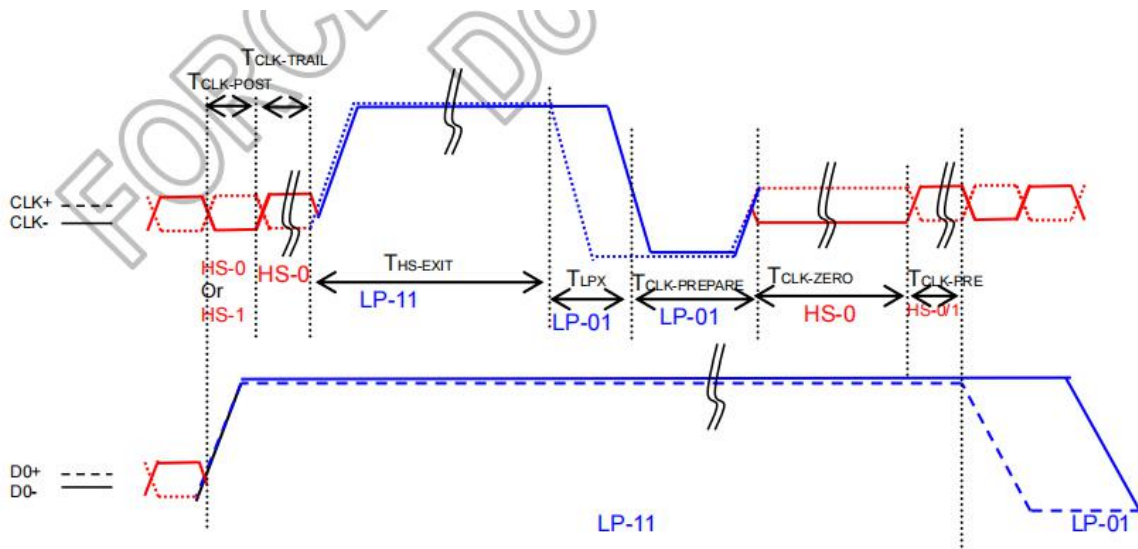
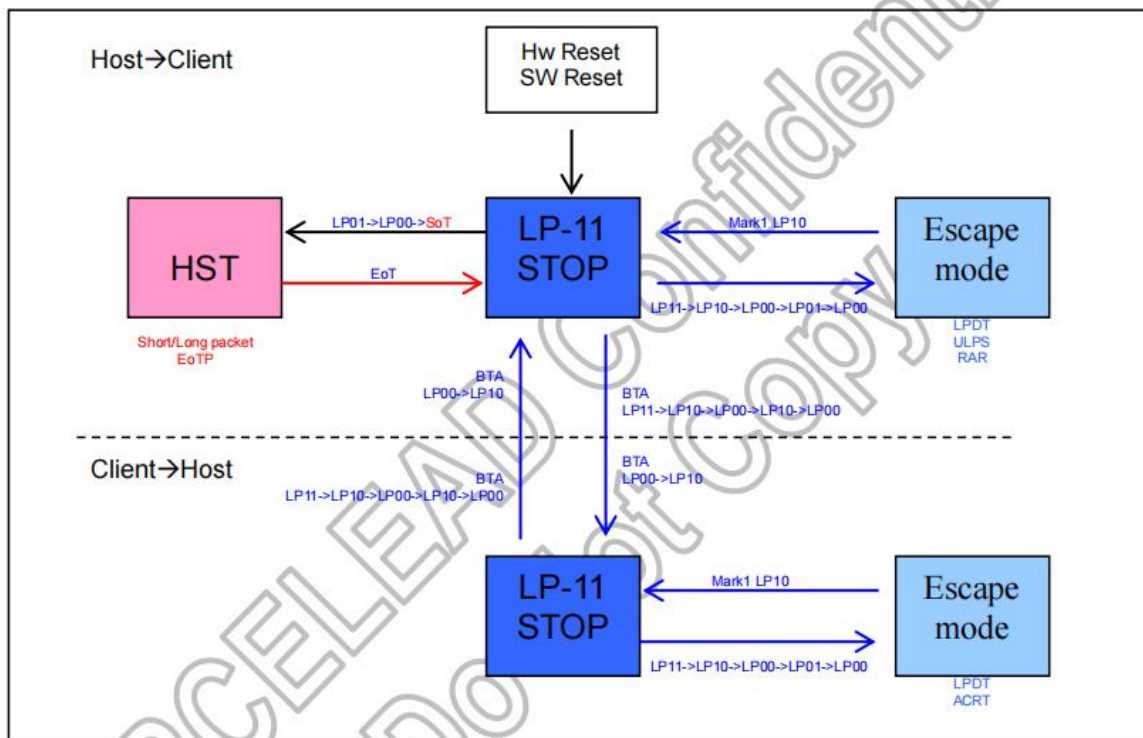

Figure 5.11: Switching the Clock Lane between HSCM and LPM

DSI-D0+/- Data Lanes can be driven in different modes which are: Escape Mode, High-Speed Data Transmission and Bus Turnaround Request. The flow chart of the D0 data lanes is illustrated below.



Description	Operation Code
High Speed Data Transmission Burst	LP11->LP01->LP00
Escape mode entry	LP11->LP10->LP00->LP01->LP00
Bus turn around	LP11->LP10->LP00->LP10->LP00
Exit Escape mode (Mark-1)	LP00->LP10->LP11

Table 5.4: Data Lane D0 Operation Modes

ESCAPE MODE

Data lanes (DSI-D0+/-) can be used in different Escape Modes when data lanes are in Low Power (LP) mode.

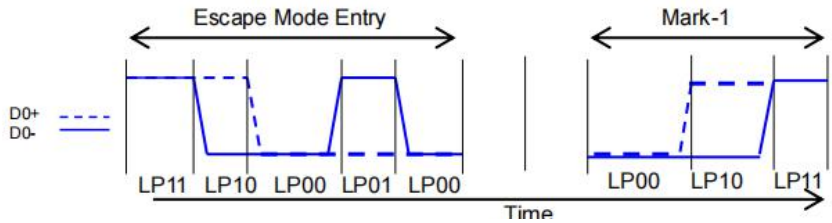

Remarks: For more information, Please check the data-sheets of ST7703

7.1.2 Power on/off timing sequence & Reset Timing Characteristics

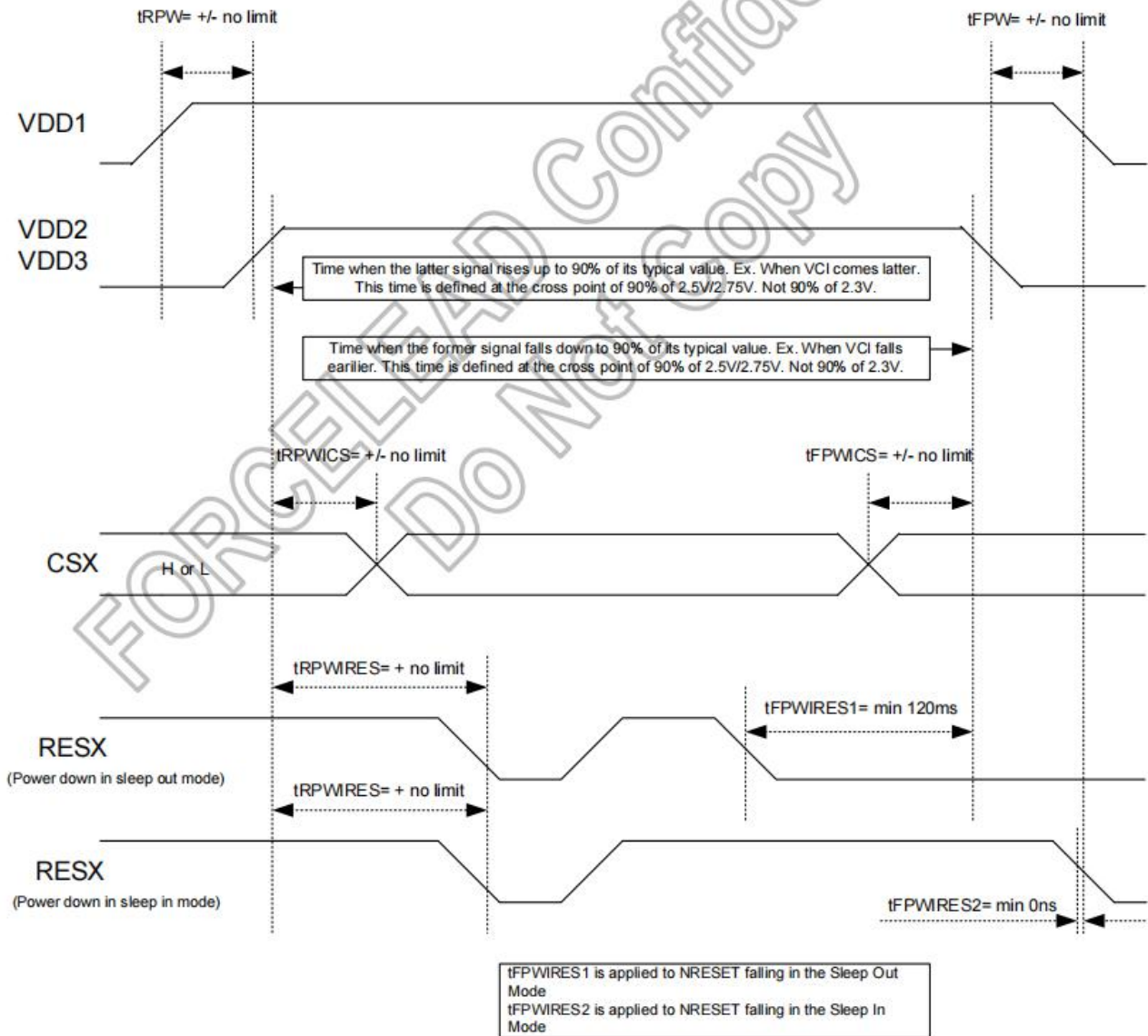

深圳市亿显国际科技有限公司 ShenZhen Yes-Display International Technology CO.,LTD.			6.0 寸液晶显示屏 6.0 Inch LCD Display Screen	
File NO.		REV	A/01	http://www.yes-display.com

8. Inspection Standard

8.1 Incoming Inspection and Standard:

The below incoming inspection are applied to the TFT LCM Modules supplied by ShenZhen Yes-Display International Technology CO.,LTD. The customers should inspect the LCM within 14 days after receiving the goods. The result of inspection should be notified to the Seller in the writing copy promptly, if the customer do not send them within 14 days, the seller has the right to judge as acceptance of goods. The inspection lot size is treated as the quantity per shipment and per model. The sampling plan shall be inspected under MIL-STD015E in Level II by single sampling. The acceptable quality level (AQL) are categorized as below grades:

CRITICAL= 0.4%, MAJOR= 0.65%, MINOR= 1.5%

8.2 Inspection condition and Warranty policy:

The delivered LCM should be stored properly, ideally under climate-controlled environment at 25 (±5) degree Celsius as well as 60% (±10) Relative Humidity. The LCM shall be inspected in the viewing angle of 45 degree from the four major angles (U/D/L/R) under the single fluorescent lamp of 20W (equal to 300 to 500 lux). For warranty, ShenZhen Yes-Display International Technology CO.,LTD. will provide 12 months of warranty period as standard, and provide the new replacement for the defective products which belong to the Seller's responsibility verified by the quality department.

8.3 Inspection Criteria:

8.3.1 Critical defect

Item No.	Inspection content	Judgement
8.3.1.1	Functional defects	No display, abnormal display, short circuit, missing line, off-contrast and chromaticity, Touch Panel non-function
8.3.1.2	Model mixed	Other model mixed

8.3.2 Major defect:

Item No.	Inspection content	Judgement
8.3.2.1	Product indication	Missing model no. and wrong model no. is indicated on the LCM.
8.3.2.2	Glass cracking	The LCD and touch panel glass crack or breakage

深圳市亿显国际科技有限公司 ShenZhen Yes-Display International Technology CO.,LTD.			6.0 寸液晶显示屏 6.0 Inch LCD Display Screen	
File NO.		REV	A/01	http://www.yes-display.com

8.3.2.3	Missing component	The function component missing such as connector, cable, etc.
---------	-------------------	---

8.3.3 Minor defect (LCD) :

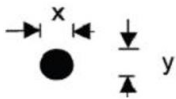
Item No.	Inspection content	Judgement												
8.3.3.1	Black/White spot Foreign particles Dust in the cell	$\varphi = (x+y) / 2$  <table border="1"> <thead> <tr> <th>Diameter (mm)</th> <th>Acceptable Q'ty</th> </tr> </thead> <tbody> <tr> <td>$\Phi \leq 0.1$</td> <td>Ignore</td> </tr> <tr> <td>$0.1 < \Phi \leq 0.25$</td> <td>3 (Distance>5mm)</td> </tr> <tr> <td>$0.25 < \Phi$</td> <td>Not allowed</td> </tr> </tbody> </table>	Diameter (mm)	Acceptable Q'ty	$\Phi \leq 0.1$	Ignore	$0.1 < \Phi \leq 0.25$	3 (Distance>5mm)	$0.25 < \Phi$	Not allowed				
Diameter (mm)	Acceptable Q'ty													
$\Phi \leq 0.1$	Ignore													
$0.1 < \Phi \leq 0.25$	3 (Distance>5mm)													
$0.25 < \Phi$	Not allowed													
8.3.3.2	Linear defect Black/white line Black/white scratch	<table border="1"> <thead> <tr> <th>Length(mm)</th> <th>Width (mm)</th> <th>Acceptable Q'ty</th> </tr> </thead> <tbody> <tr> <td></td> <td>$W \leq 0.03$</td> <td>Ignore</td> </tr> <tr> <td>$L \leq 5.0$</td> <td>$0.03 < W \leq 0.07$</td> <td>3</td> </tr> <tr> <td></td> <td>$0.07 < W$</td> <td>Follow 8.3.3.1</td> </tr> </tbody> </table>	Length(mm)	Width (mm)	Acceptable Q'ty		$W \leq 0.03$	Ignore	$L \leq 5.0$	$0.03 < W \leq 0.07$	3		$0.07 < W$	Follow 8.3.3.1
Length(mm)	Width (mm)	Acceptable Q'ty												
	$W \leq 0.03$	Ignore												
$L \leq 5.0$	$0.03 < W \leq 0.07$	3												
	$0.07 < W$	Follow 8.3.3.1												
8.3.3.3	Polarizer Bubbles Dent on polarizer	<table border="1"> <thead> <tr> <th>Diameter (mm)</th> <th>Acceptable Q'ty</th> </tr> </thead> <tbody> <tr> <td>$\Phi \leq 0.2$</td> <td>Ignore</td> </tr> <tr> <td>$0.2 < \Phi \leq 0.5$</td> <td>2 (Distance>5mm)</td> </tr> <tr> <td>$0.5 < \Phi$</td> <td>Not allowed</td> </tr> </tbody> </table>	Diameter (mm)	Acceptable Q'ty	$\Phi \leq 0.2$	Ignore	$0.2 < \Phi \leq 0.5$	2 (Distance>5mm)	$0.5 < \Phi$	Not allowed				
Diameter (mm)	Acceptable Q'ty													
$\Phi \leq 0.2$	Ignore													
$0.2 < \Phi \leq 0.5$	2 (Distance>5mm)													
$0.5 < \Phi$	Not allowed													

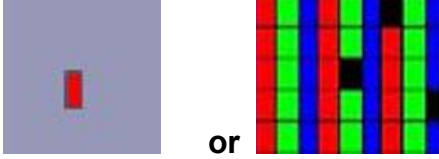
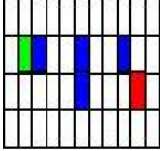
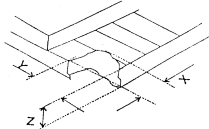
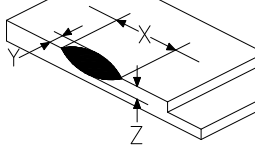
<p>8.3.3.4</p>	<p>Electrical Defect Dot</p>	<p>Bright dot and Dark dot definition:</p>  <p>or</p>  <p>(Two adjacent dot)</p> <p>Inspection pattern: black, white, red, green, and blue screen.</p> <table border="1" data-bbox="730 730 1441 913"> <thead> <tr> <th>Items</th> <th>Acceptable Q'ty</th> </tr> </thead> <tbody> <tr> <td>Bright dot</td> <td>$N \leq 4$ (Distance >5mm)</td> </tr> <tr> <td>Dark dot</td> <td>$N \leq 4$ (Distance >5mm)</td> </tr> </tbody> </table>	Items	Acceptable Q'ty	Bright dot	$N \leq 4$ (Distance >5mm)	Dark dot	$N \leq 4$ (Distance >5mm)
Items	Acceptable Q'ty							
Bright dot	$N \leq 4$ (Distance >5mm)							
Dark dot	$N \leq 4$ (Distance >5mm)							
<p>8.3.3.5</p>	<p>Glass Defect- Corner chipping</p>	 <table border="1" data-bbox="730 1104 1441 1375"> <thead> <tr> <th>Size(mm)</th> <th>Judgement</th> </tr> </thead> <tbody> <tr> <td> $X \leq 3\text{mm}$, $Y \leq S$, $Z \leq T$ (S= ITO length, T=Single glass thickness) </td> <td>Accept</td> </tr> </tbody> </table>	Size(mm)	Judgement	$X \leq 3\text{mm}$, $Y \leq S$, $Z \leq T$ (S= ITO length, T=Single glass thickness)	Accept		
Size(mm)	Judgement							
$X \leq 3\text{mm}$, $Y \leq S$, $Z \leq T$ (S= ITO length, T=Single glass thickness)	Accept							
<p>8.3.3.6</p>	<p>Glass Defect- Side fragment</p>	 <table border="1" data-bbox="730 1574 1441 1787"> <thead> <tr> <th>Size(mm)</th> <th>Judgement</th> </tr> </thead> <tbody> <tr> <td> $X \leq 2 \text{ mm}$, $Y \leq \text{border edge}$ $Z \leq T$ (T= single glass thickness) </td> <td>Accept</td> </tr> </tbody> </table>	Size(mm)	Judgement	$X \leq 2 \text{ mm}$, $Y \leq \text{border edge}$ $Z \leq T$ (T= single glass thickness)	Accept		
Size(mm)	Judgement							
$X \leq 2 \text{ mm}$, $Y \leq \text{border edge}$ $Z \leq T$ (T= single glass thickness)	Accept							

8.3.4 Minor defect (Touch Panel)

Item No.	Inspection content	Judgement
----------	--------------------	-----------

File NO.

REV

A/01

<http://www.yes-display.com>

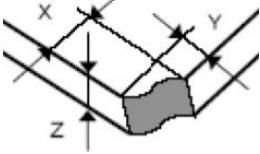
8.3.4.1	Scratch, dust, particles, foreign materials in "linear type"	<table border="1"> <thead> <tr> <th>Size (mm)</th> <th>Acceptable Q'ty</th> </tr> </thead> <tbody> <tr> <td>$W \leq 0.05\text{mm}, L \leq 10\text{mm}$</td> <td>Ignore</td> </tr> <tr> <td>$0.05\text{mm} < W \leq 0.07\text{mm}, L \leq 10\text{mm}$</td> <td>3</td> </tr> <tr> <td>$W > 0.07\text{mm}$</td> <td>Reject</td> </tr> </tbody> </table>	Size (mm)	Acceptable Q'ty	$W \leq 0.05\text{mm}, L \leq 10\text{mm}$	Ignore	$0.05\text{mm} < W \leq 0.07\text{mm}, L \leq 10\text{mm}$	3	$W > 0.07\text{mm}$	Reject
Size (mm)	Acceptable Q'ty									
$W \leq 0.05\text{mm}, L \leq 10\text{mm}$	Ignore									
$0.05\text{mm} < W \leq 0.07\text{mm}, L \leq 10\text{mm}$	3									
$W > 0.07\text{mm}$	Reject									
8.3.4.2	Scratch, dust, particles, foreign materials in "round type"	<table border="1"> <thead> <tr> <th>Diameter (mm)</th> <th>Acceptable Q'ty</th> </tr> </thead> <tbody> <tr> <td>$\Phi \leq 0.25\text{mm}$</td> <td>Ignore</td> </tr> <tr> <td>$0.25\text{mm} < \Phi \leq 0.35\text{mm}$</td> <td>5</td> </tr> <tr> <td>$\Phi > 0.35\text{mm}$</td> <td>Reject</td> </tr> </tbody> </table>	Diameter (mm)	Acceptable Q'ty	$\Phi \leq 0.25\text{mm}$	Ignore	$0.25\text{mm} < \Phi \leq 0.35\text{mm}$	5	$\Phi > 0.35\text{mm}$	Reject
Diameter (mm)	Acceptable Q'ty									
$\Phi \leq 0.25\text{mm}$	Ignore									
$0.25\text{mm} < \Phi \leq 0.35\text{mm}$	5									
$\Phi > 0.35\text{mm}$	Reject									
8.3.4.3	Air bubbles	<table border="1"> <thead> <tr> <th>Diameter (mm)</th> <th>Acceptable Q'ty</th> </tr> </thead> <tbody> <tr> <td>$\Phi \leq 0.2\text{mm}$</td> <td>Ignore</td> </tr> <tr> <td>$0.2\text{mm} < \Phi \leq 0.5\text{mm}$</td> <td>3</td> </tr> <tr> <td>$\Phi > 0.5\text{mm}$</td> <td>Reject</td> </tr> </tbody> </table>	Diameter (mm)	Acceptable Q'ty	$\Phi \leq 0.2\text{mm}$	Ignore	$0.2\text{mm} < \Phi \leq 0.5\text{mm}$	3	$\Phi > 0.5\text{mm}$	Reject
Diameter (mm)	Acceptable Q'ty									
$\Phi \leq 0.2\text{mm}$	Ignore									
$0.2\text{mm} < \Phi \leq 0.5\text{mm}$	3									
$\Phi > 0.5\text{mm}$	Reject									
8.3.4.5	Scratch on printing area	<table border="1"> <thead> <tr> <th>Size (mm)</th> <th>Acceptable Q'ty</th> </tr> </thead> <tbody> <tr> <td>$W \leq 0.03\text{mm}, L \leq 5\text{mm}$</td> <td>Ignore</td> </tr> <tr> <td>$0.03\text{mm} < W \leq 0.05\text{mm}, L \leq 5\text{mm}$</td> <td>3</td> </tr> <tr> <td>$W > 0.05\text{mm}$ or $L > 5\text{mm}$</td> <td>Reject</td> </tr> </tbody> </table>	Size (mm)	Acceptable Q'ty	$W \leq 0.03\text{mm}, L \leq 5\text{mm}$	Ignore	$0.03\text{mm} < W \leq 0.05\text{mm}, L \leq 5\text{mm}$	3	$W > 0.05\text{mm}$ or $L > 5\text{mm}$	Reject
Size (mm)	Acceptable Q'ty									
$W \leq 0.03\text{mm}, L \leq 5\text{mm}$	Ignore									
$0.03\text{mm} < W \leq 0.05\text{mm}, L \leq 5\text{mm}$	3									
$W > 0.05\text{mm}$ or $L > 5\text{mm}$	Reject									
8.3.4.6	Corner chipping	 <table border="1"> <thead> <tr> <th>Size(mm)</th> <th>Judgement</th> </tr> </thead> <tbody> <tr> <td>$X \leq 2\text{mm}, Y \leq 2\text{mm}$ $Z < 1/2T$ (T= single glass thickness)</td> <td>Accept</td> </tr> </tbody> </table>	Size(mm)	Judgement	$X \leq 2\text{mm}, Y \leq 2\text{mm}$ $Z < 1/2T$ (T= single glass thickness)	Accept				
Size(mm)	Judgement									
$X \leq 2\text{mm}, Y \leq 2\text{mm}$ $Z < 1/2T$ (T= single glass thickness)	Accept									

File NO.

REV

A/01

<http://www.yes-display.com>

8.3.4.7

Edge chipping

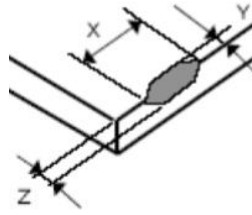

Size(mm)	Judgement
$X \leq 3 \text{ mm}, Y \leq 3 \text{ mm}$ $Z \leq 1/2 T$ (T= single glass thickness)	Accept

深圳市亿显国际科技有限公司 ShenZhen Yes-Display International Technology CO.,LTD.			6.0 寸液晶显示屏 6.0 Inch LCD Display Screen	
File NO.		REV	A/01	http://www.yes-display.com

9. Reliability Test Conditions and Methods

9.1 Reliability Test Conditions and Methods:

NO.	TEST ITEMS	TEST CONDITION	INSPECTION AFTER TEST
①	High Temperature Storage	80°C±2°C×96Hours	Inspection after 2~4hours storage at room temperature, the samples should be free from defects: 1, Air bubble in the LCD. 2, Seal leak. 3, Non-display. 4, Missing segments. 5, Glass crack. 6, Current IDD is twice higher than initial value. 7, The surface shall be free from damage. 8, The electric characteristic requirements shall be satisfied.
②	Low Temperature Storage	-30°C±2°C×96Hours	
③	High Temperature Operating	70°C±2°C×96Hours	
④	Low Temperature Operating	-20°C±2°C×96Hours	
⑤	Temperature Cycle(Storage)	$ \begin{array}{c} -20^{\circ}\text{C} \longleftrightarrow 25^{\circ}\text{C} \longleftrightarrow 70^{\circ}\text{C} \\ (30\text{min}) \longleftarrow (5\text{min}) \longrightarrow (30\text{min}) \\ \text{1cycle} \\ \text{Total 10cycle} \end{array} $	
⑥	Damp Proof Test (Storage)	50°C±5°C×90%RH×96Hours	
⑦	Vibration Test	Frequency:10Hz~55Hz~10Hz Amplitude:1.5MM X,Y,Z direction for total 3hours (packing condition test will be tested by a carton)	
⑧	Drooping Test	Drop to the ground from 1M height one time every side of carton. (packing condition test will be tested by a carton)	
⑨	ESD Test	Voltage:±8KV,R:330Ω,C:150PF,Air Mode,10times	

深圳市亿显国际科技有限公司 ShenZhen Yes-Display International Technology CO.,LTD.			6.0 寸液晶显示屏 6.0 Inch LCD Display Screen	
File NO.		REV	A/01	http://www.yes-display.com

REMARK:

- 1, The Test samples should be applied to only one test item.
- 2, Sample side for each test item is 5~10pcs.
- 3, For Damp Proof Test, Pure water (Resistance > 10MΩ) should be used.
- 4, In case of malfunction defect caused by ESD damage, if it would be recovered to normal state after resetting, it would be judge as a good part.
- 5, EL evaluation should be accepted from reliability test with humidity and temperature: Some defects such as black spot/blemish can happen by natural chemical reaction with humidity and Fluorescence EL has.
- 6, Failure Judgment Criterion: Basic Specification Electrical Characteristic, Mechanical Characteristic, Optical Characteristic.

深圳市亿显国际科技有限公司 ShenZhen Yes-Display International Technology CO.,LTD.			6.0 寸液晶显示屏 6.0 Inch LCD Display Screen	
File NO.		REV	A/01	http://www.yes-display.com

10. Cautions and Handling Precautions

10.1 Mounting method

The LCD panel of TFT module consists of two thin glass plates with polarizes which easily be damaged. And since the module in so constructed as to be fixed by utilizing fitting holes in the printed circuit board.

Extreme care should be needed when handling the LCD modules.

10.2 Caution of LCD handling and cleaning

When cleaning the display surface, Use soft cloth with solvent

[Recommended below] and wipe lightly

- Isopropyl alcohol
- Ethyl alcohol

Do not wipe the display surface with dry or hard materials that will damage the polarizer surface.

Do not use the following solvent:

- Water
- Aromatics

Do not wipe ITO pad area with the dry or hard materials that will damage the ITO patterns

Do not use the following solvent on the pad or prevent it from being contaminated:

- Soldering flux
- Chlorine (Cl) , Sulfur (S)

If goods were sent without being silicon coated on the pad, ITO patterns could be damaged due to the corrosion as time goes on.

If ITO corrosion happen by miss-handling or using some materials such as Chlorine (Cl), Sulfur (S) from customer, Responsibility is on customer.

10.3 Caution against static charge

The LCD module use C-MOS LSI drivers, so we recommended that you:

Connect any unused input terminal to power or ground, do not input any signals before power is turned on, and ground your body, work/assembly areas, and assembly equipment to protect against static electricity.

深圳市亿显国际科技有限公司 ShenZhen Yes-Display International Technology CO.,LTD.			6.0 寸液晶显示屏 6.0 Inch LCD Display Screen	
File NO.		REV	A/01	http://www.yes-display.com

10.4 packing

- Module employs LCD elements and must be treated as such.
- Avoid intense shock and falls from a height.
- To prevent modules from degradation, do not operate or store them exposed direct to sunshine or high temperature/humidity

10.5 Caution for operation

- It is an indispensable condition to drive LCD's within the specified voltage limit since the higher voltage then the limit cause the shorter LCD life.
- An electrochemical reaction due to direct current causes LCD's undesirable deterioration, so that the use of direct current drive should be avoided.
- Response time will be extremely delayed at lower temperature then the operating temperature range and on the other hand at higher temperature LCD's how dark color in them. However those phenomena do not mean malfunction or out of order with LCD's, which will come back in the specified operation temperature.
- If the display area is pushed hard during operation, some font will be abnormally displayed but it resumes normal condition after turning off once.
- Slight dew depositing on terminals is a cause for electro-chemical reaction resulting in terminal open circuit.

Usage under the maximum operating temperature, 50%Rh or less is required.

10.6 storing

In the case of storing for a long period of time for instance, for years for the purpose or replacement use, the following ways are recommended.

- Storage in a polyethylene bag with the opening sealed so as not to enter fresh air outside in it. And with no desiccant.
- Placing in a dark place where neither exposure to direct sunlight nor light's keeping the storage temperature range.
- Storing with no touch on polarizer surface by the anything else.

[It is recommended to store them as they have been contained in the inner container at the time of delivery from us

10.7 Safety

- It is recommendable to crash damaged or unnecessary LCD's into pieces and wash off liquid crystal by either of solvents such as acetone and ethanol, which should be burned up later.

深圳市亿显国际科技有限公司 ShenZhen Yes-Display International Technology CO.,LTD.			6.0 寸液晶显示屏 6.0 Inch LCD Display Screen	
File NO.		REV	A/01	http://www.yes-display.com

- When any liquid leaked out of a damaged glass cell comes in contact with your hands, please wash it off well with soap and water

11. Packing Method

11.1 Method

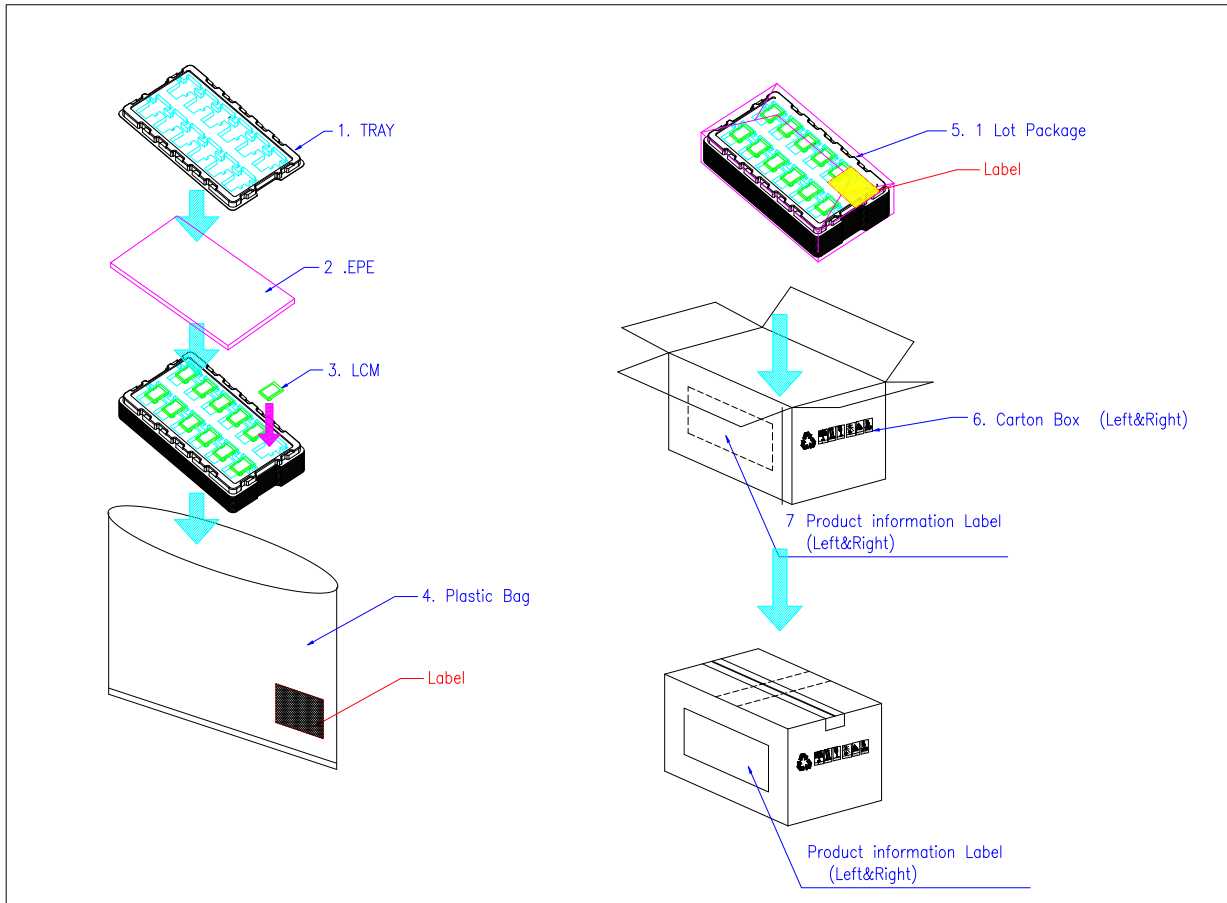

11.2 Packing Label

TBD