

深圳市亿显国际科技有限公司 ShenZhen Yes-Display International Technology CO.,LTD.			2.9 寸液晶显示屏 2.9 Inch LCD Display Screen	
File NO.		REV	A/01	http://www.yes-display.com

SPECIFICATION FOR

Module:YS-T029001 V1.0

Designed by	R&D Checked by	Quality Department by	Approved by

Approval by Customer:

OK

NG, Problem survey

Approved By _____

Revision Record

深圳市亿显国际科技有限公司 ShenZhen Yes-Display International Technology CO.,LTD.			2.9 寸液晶显示屏 2.9 Inch LCD Display Screen	
File NO.		REV	A/01	http://www.yes-display.com

Contents

List	Description	Page No.
	Cover	1
	Revision Record	2
	Contents	3
1	Technical parameters	4
2	Block Dimension	5
3	Outline Dimensions	6
4	Input terminal Pin Assignment Description	7
5	LCD Optical Characteristics	8
6	TFT Electrical Characteristics	11
7	Timing Characteristics	13
8	Inspection Standard	16
9	Reliability Test Conditions and Methods	21
10	Cautions and Handling Precautions	23
11	Packing Method	26

深圳市亿显国际科技有限公司 ShenZhen Yes-Display International Technology CO.,LTD.			2.9 寸液晶显示屏 2.9 Inch LCD Display Screen	
File NO.		REV	A/01	http://www.yes-display.com

1. Technical parameters

ITEM	STANDARD VALUES	UNITS
LCD type	2.9 TFT	--
Dot arrangement	320(RGB)×120	dots
Color filter array	RGB vertical stripe	--
Display mode	TN / Transmission / Normally White	-
Eyes Viewing Direction	6:00	--
Driver IC	-	--
Module size	76.84(W)×38.22(H)×3.26(T)(Exclude FPC)	mm
Active area	70.08(W)×26.46(H)	mm
Interface	RGB	--
Operating temperature	-20 ~ +70	°C
Storage temperature	-30 ~ +80	°C
Back Light	White LED*6	--

2. Block Dimension

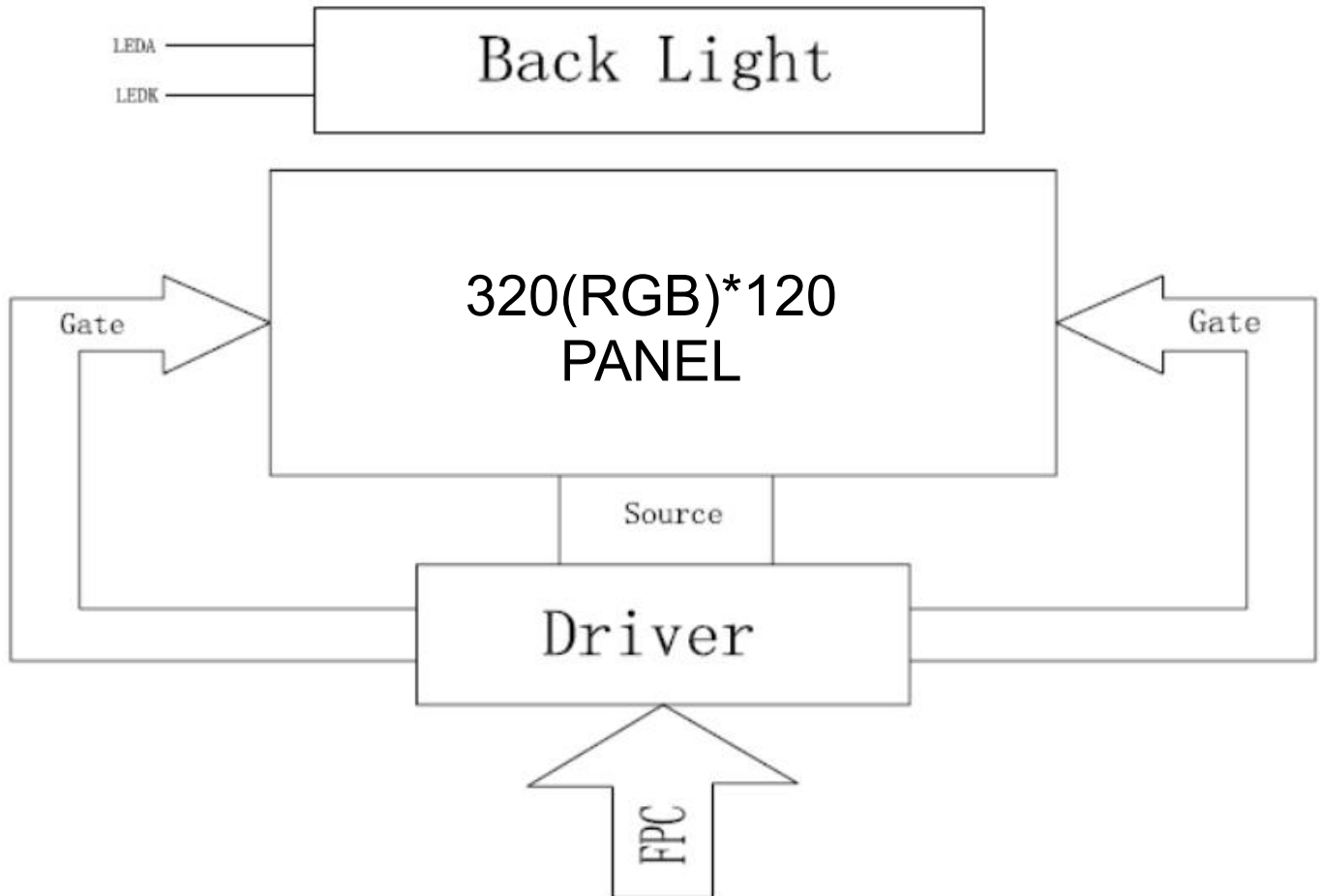

3. Outline Dimensions

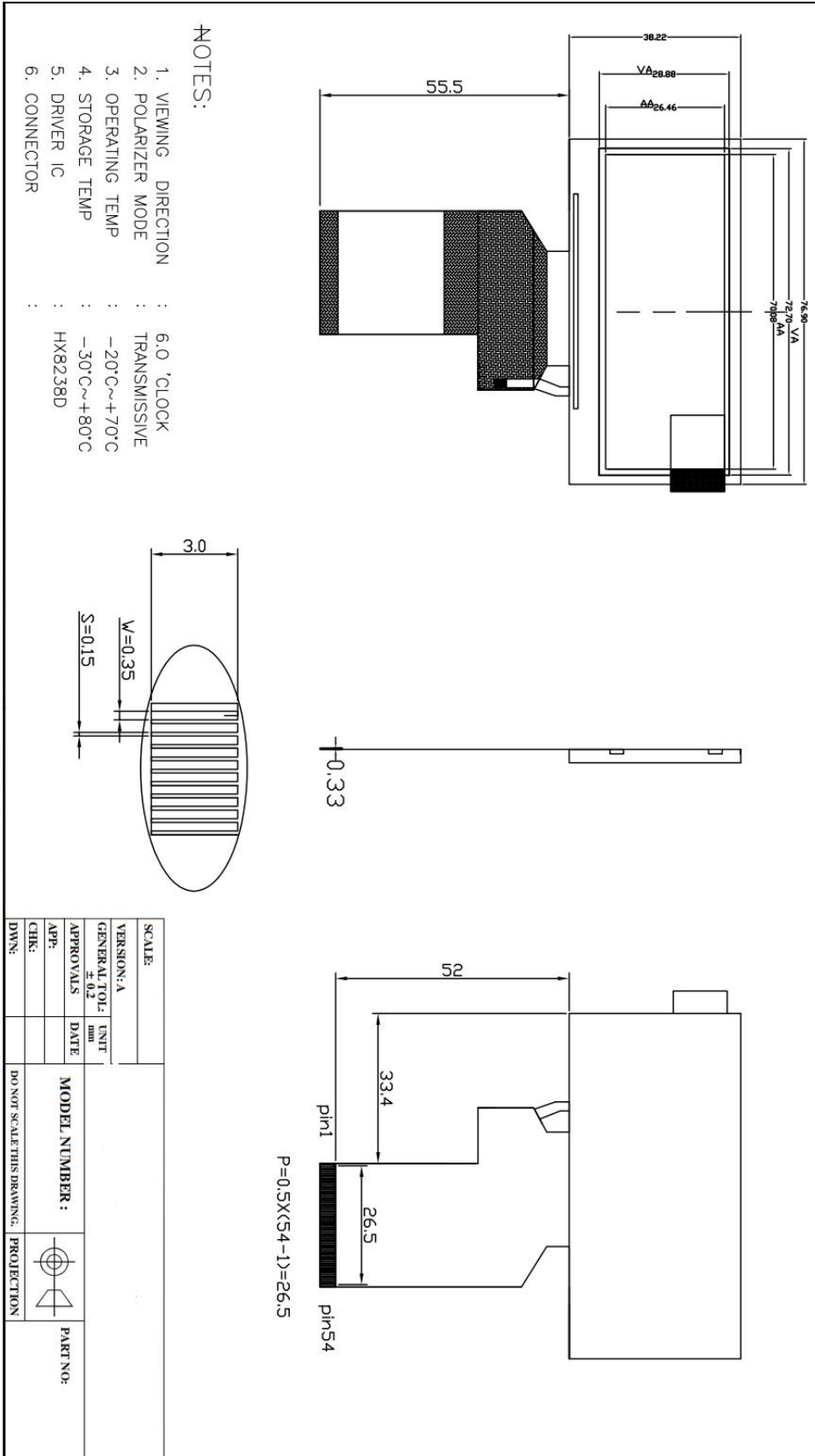

深圳市亿显国际科技有限公司 ShenZhen Yes-Display International Technology CO.,LTD.			2.9 寸液晶显示屏 2.9 Inch LCD Display Screen	
File NO.		REV	A/01	http://www.yes-display.com

4. Input terminal Pin Assignment Description

4.1 TFT Pin Description

PIN NO.	PIN NAME	DESCRIPTION
1-2	LEDK	Power supply for backlight cathode input terminal.
3-4	LEDA	Power supply for backlight anode input terminal.
5-7	NC	NC
8	RESET	Reset signal input terminal, active at 'L'.
9	CS	Chip select input pin ("Low" enable).
10	SCL	This pin is used serial interface clock in SPI
11	SDA	Serial input signal in SPI I/F.
12-19	B0-B7	Data.
20-27	G0-G7	Data.
28-35	R0-R7	Data.
36	HS	Horizontal sync input. Negative polarity.
37	VS	Vertical sync input. Negative polarity.
38	DCLK	Dot clock signal input. Latching input data at its rising edge.
39-40	NC	NC
41	IOVCC1.8	IOVCC power input
42	VCC2.8	VCC power input
43-47	NC	NC
48-50	SEL2-SEL0	MPU Parallel interface bus and serial interface select
51	NC	NC
52	DEN	
53	GND	Ground for logic.
54	GND	Ground for logic.

4.2 TP Pin Description

TBD

5. LCD Optical Characteristics

ITEM	SYMBOL	CONDITION	MIN.	TYP.	MAX.	
Color Filter Chromaticity	White	x y	$\theta=\phi=0^\circ$	0.289	0.309	0.329
				0.32	0.34	0.36
	Red	x y	$\theta=\phi=0^\circ$	0.633	0.653	0.673
				0.311	0.331	0.351
	Green	x y	$\theta=\phi=0^\circ$	0.295	0.315	0.335
				0.554	0.574	0.594
	Blue	x y	$\theta=\phi=0^\circ$	0.118	0.138	0.158
				0.113	0.133	0.153
	Gamut			60.7%		
	Measured by C light					
Transmittance		$\theta=\phi=0^\circ$	5.6%	6.0%		
Measured by GP standard backlight						

Note (1) Measurement Setup: The LCD module should be stabilized at given temp. 25°C for 15 minutes to avoid abrupt temperature change during measuring. In order to stabilize the luminance, the measurement should be executed after lighting backlight for 15 minutes in a windless room.

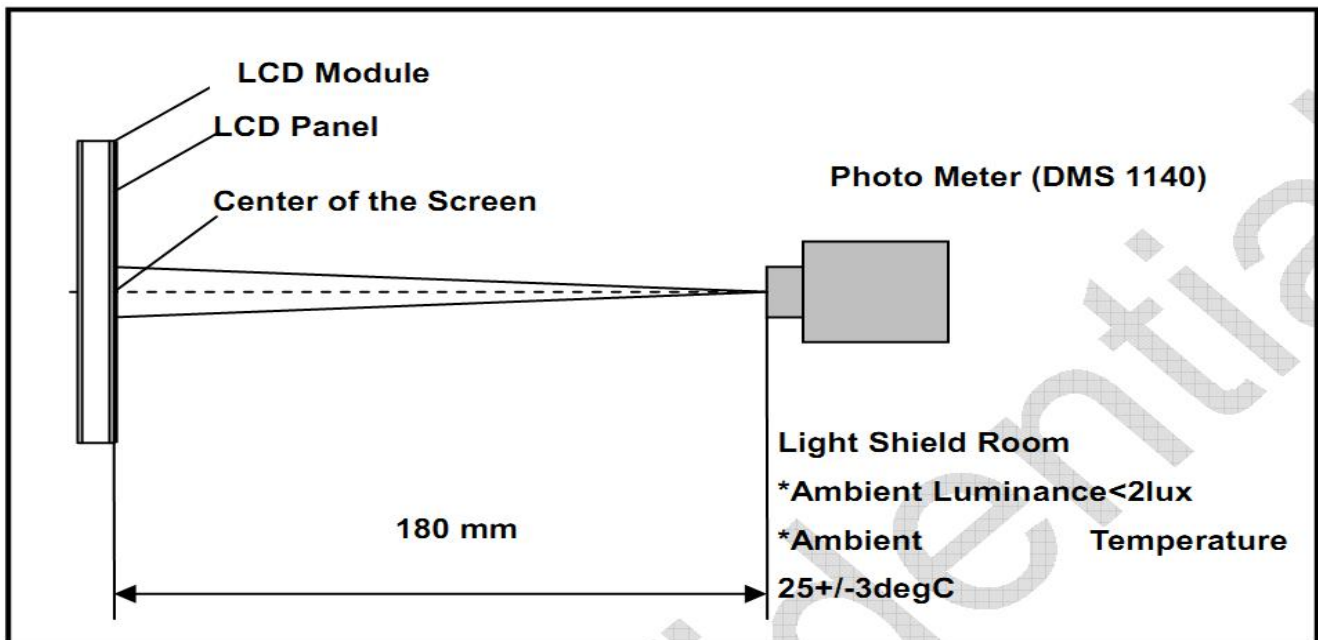

Note (2) Definition of Viewing Angle

深圳市亿显国际科技有限公司 ShenZhen Yes-Display International Technology CO.,LTD.			2.9 寸液晶显示屏 2.9 Inch LCD Display Screen	
File NO.		REV	A/01	http://www.yes-display.com

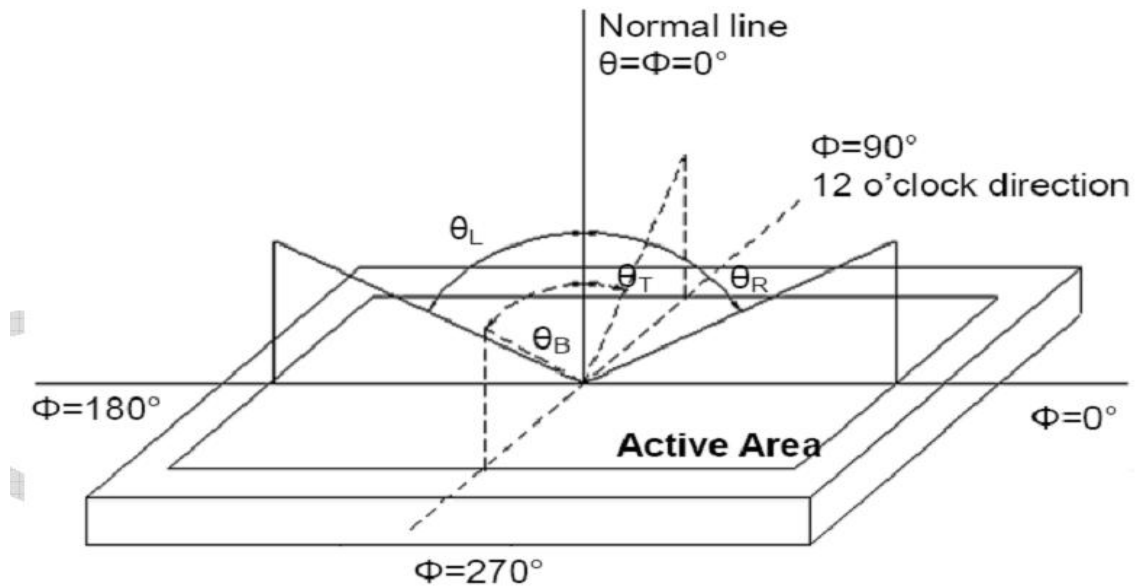

Note (3) Definition of Contrast Ratio (CR)

The contrast ratio can be calculated by the following expression

$$\text{Contrast Ratio (CR)} = L63 / L0$$

L63: Luminance of gray level 63, L0: Luminance of gray level 0

Note (4) Definition of response time

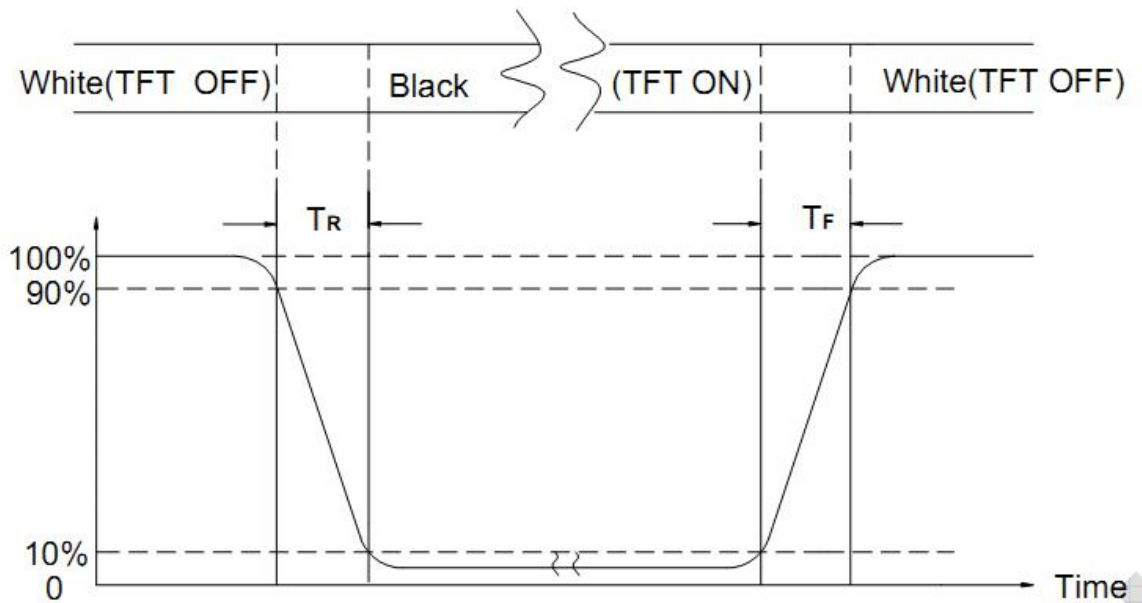

Note (5) Definition of Transmittance (Module is without signal input)

$$\text{Transmittance} = \text{Center Luminance of LCD} / \text{Center Luminance of Back Light} \times 100\%$$

Note (6) Definition of color chromaticity (CIE1931)

深圳市亿显国际科技有限公司 ShenZhen Yes-Display International Technology CO.,LTD.			2.9 寸液晶显示屏 2.9 Inch LCD Display Screen	
File NO.		REV	A/01	http://www.yes-display.com

Color coordinates measured at the center point of LCD

深圳市亿显国际科技有限公司 ShenZhen Yes-Display International Technology CO.,LTD.			2.9 寸液晶显示屏 2.9 Inch LCD Display Screen	
File NO.		REV	A/01	http://www.yes-display.com

6. TFT Electrical Characteristics

6.1 Absolute Maximum Ratings

Item	Symbol	Min.	Max.	Unit
Logic Supply Voltage	VDD	-0.3	4.0	V
Input Voltage	V _{in}	-0.3	VDD+0.3	V
Operating Temperature	T _{OP}	-20	70	°C
Storage Temperature	T _{ST}	-30	80	°C
Storage Humidity	HD	20	90	%RH

6.2 DC Characteristics

Item	Symbol	Min.	Typ.	Max.	Unit	Remark
Logic Supply Voltage	VDD	2.5	2.8	3.6	V	-
Input High Voltage	V _{IH}	0.7VDD	-	VDD	V	-
Input Low Voltage	V _{IL}	GND	-	0.3 VDD	V	-
Output High Voltage	V _{OH}	0.8 VDD	-	VDD	V	-
Output Low Voltage	V _{OL}	GND	-	0.2 VDD	V	-
I/O Leak Current	I _{LI}	-1	-	1	uA	-
Supply Current	IDD	-	TBD	-	mA	-

6.3 LED Backlight Characteristics

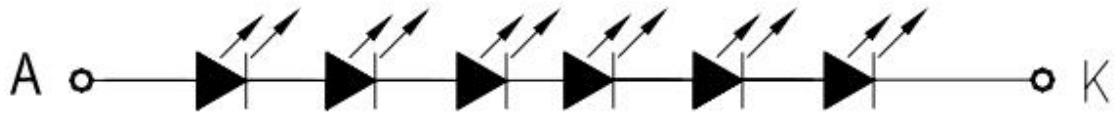

Item	Symbol	MIN	TYP	MAX	UNIT	Test Condition
Supply Voltage	Vf	16.8	18	19.2	V	If=20mA
Supply Current	If	-	20	-	mA	-
Luminous Intensity for LCM	-	250	300	-	cd/m ²	If=20mA
Uniformity for LCM	-	-	60	-	%	If=20mA
Life Time	-	-	50000	-	Hr	If=20mA
Backlight Color	White					

7. Timing Characteristics

7.1 TFT Timing Characteristics

7.1.1 Display Serial Interface Timing Characteristics (RGB 8080 system)

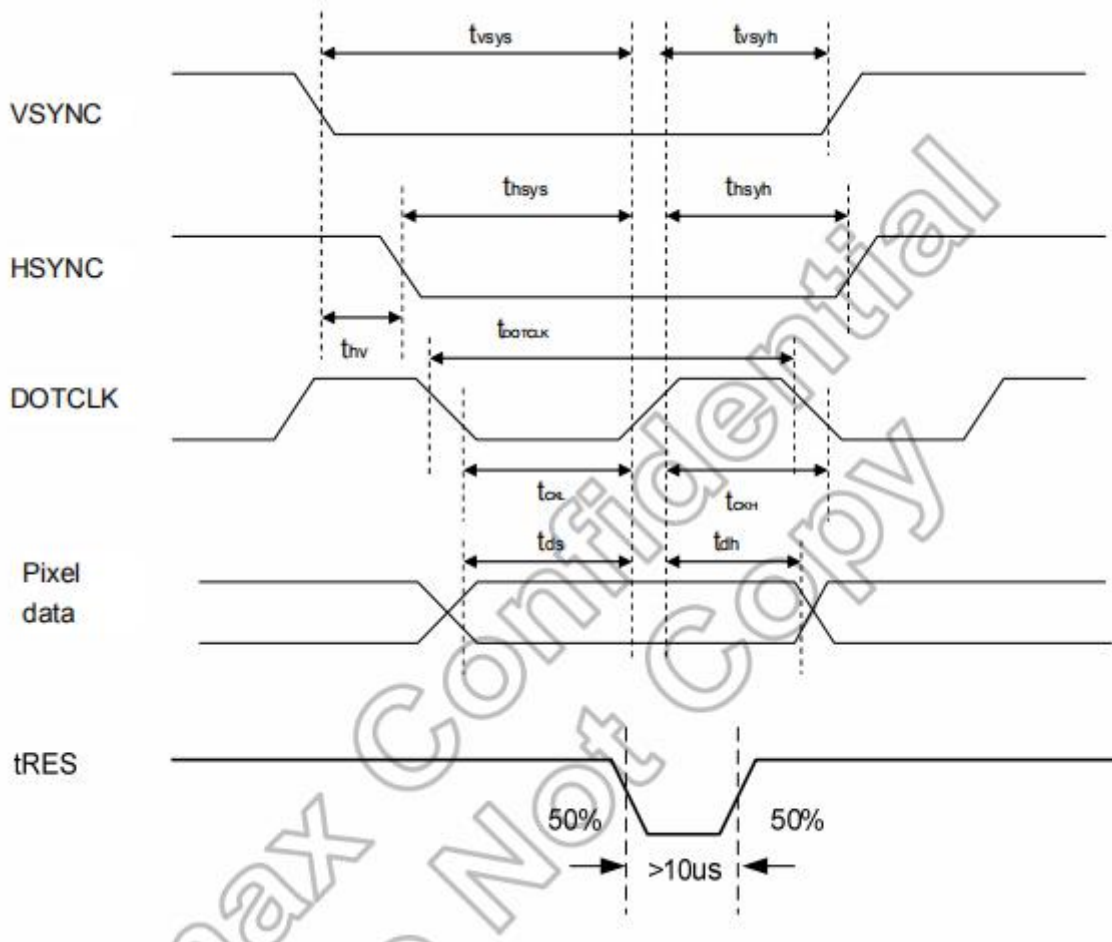

Signal	Symbol	Parameter	Min	Max	Unit	Description
DB[17:0]	TDST	Data Setup Time	20	--	ns	TRAT, TRATFM: 3K ohm Pull up or Down and 30pF Parallel Cap. To GND. TODH: 3K ohm Pull up or Down.
	TDHT	Data Hold Time	10	--	ns	
	TRAT	Read Access Time (ID)	--	150	ns	
	TODH	Output Disable Time	10	--	ns	

Table 3 8080 Parallel Interface Characteristics

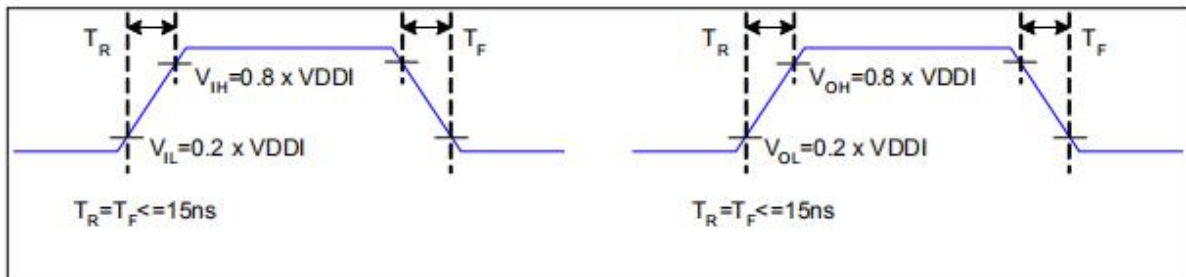
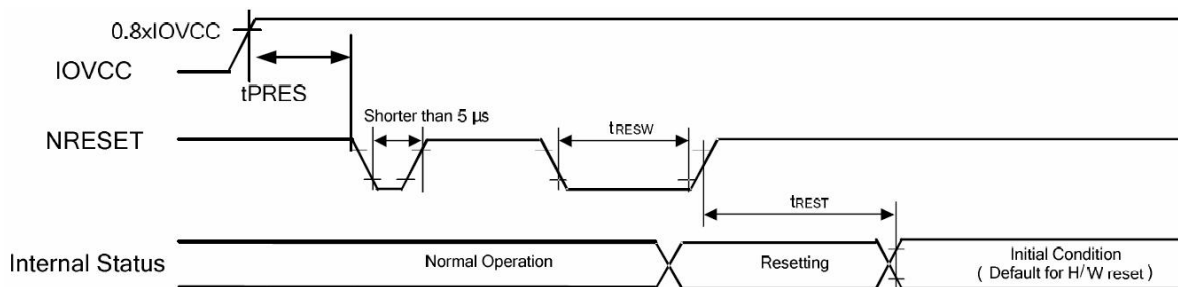

Figure 3 Rising and Falling Timing for I/O Signal

Note: The rising time and falling time (T_r , T_f) of input signal and fall time are specified at 15 ns or less. Logic high and low levels are specified as 20% and 80% of VDDI for Input signals.

7.1.2 Reset Timing Characteristics



7.1.3 Power on/off timing sequence check the IC datasheet!

7.2 TP Timing Characteristics

TBD

深圳市亿显国际科技有限公司 ShenZhen Yes-Display International Technology CO.,LTD.			2.9 寸液晶显示屏 2.9 Inch LCD Display Screen	
File NO.		REV	A/01	http://www.yes-display.com

8. Inspection Standard

8.1 Incoming Inspection and Standard:

The below incoming inspection are applied to the TFT LCM Modules supplied by ShenZhen Yes-Display International Technology CO.,LTD. The customers should inspect the LCM within 14 days after receiving the goods. The result of inspection should be notified to the Seller in the writing copy promptly, if the customer do not send them within 14 days, the seller has the right to judge as acceptance of goods. The inspection lot size is treated as the quantity per shipment and per model. The sampling plan shall be inspected under MIL-STD015E in Level II by single sampling. The acceptable quality level (AQL) are categorized as below grades:

CRITICAL= 0.4%, MAJOR= 0.65%, MINOR= 1.5%

8.2 Inspection condition and Warranty policy:

The delivered LCM should be stored properly, ideally under climate-controlled environment at 25 (±5) degree Celsius as well as 60% (±10) Relative Humidity. The LCM shall be inspected in the viewing angle of 45 degree from the four major angles (U/D/L/R) under the single fluorescent lamp of 20W (equal to 300 to 500 lux). For warranty, ShenZhen Yes-Display International Technology CO.,LTD. will provide 12 months of warranty period as standard, and provide the new replacement for the defective products which belong to the Seller's responsibility verified by the quality department.

8.3 Inspection Criteria:

8.3.1 Critical defect

Item No.	Inspection content	Judgement
8.3.1.1	Functional defects	No display, abnormal display, short circuit, missing line, off-contrast and chromaticity, Touch Panel non-function
8.3.1.2	Model mixed	Other model mixed

8.3.2 Major defect:

Item No.	Inspection content	Judgement
8.3.2.1	Product indication	Missing model no. and wrong model no. is indicated on the LCM.
8.3.2.2	Glass cracking	The LCD and touch panel glass crack or breakage

深圳市亿显国际科技有限公司 ShenZhen Yes-Display International Technology CO.,LTD.			2.9 寸液晶显示屏 2.9 Inch LCD Display Screen	
File NO.		REV	A/01	http://www.yes-display.com

8.3.2.3	Missing component	The function component missing such as connector, cable, etc.
---------	-------------------	---

8.3.3 Minor defect (LCD) :

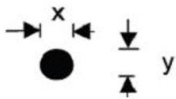
Item No.	Inspection content	Judgement												
8.3.3.1	Black/White spot Foreign particles Dust in the cell	$\phi = (x+y) / 2$  <table border="1"> <thead> <tr> <th>Diameter (mm)</th> <th>Acceptable Q'ty</th> </tr> </thead> <tbody> <tr> <td>$\Phi \leq 0.1$</td> <td>Ignore</td> </tr> <tr> <td>$0.1 < \Phi \leq 0.25$</td> <td>3 (Distance>5mm)</td> </tr> <tr> <td>$0.25 < \Phi$</td> <td>Not allowed</td> </tr> </tbody> </table>	Diameter (mm)	Acceptable Q'ty	$\Phi \leq 0.1$	Ignore	$0.1 < \Phi \leq 0.25$	3 (Distance>5mm)	$0.25 < \Phi$	Not allowed				
Diameter (mm)	Acceptable Q'ty													
$\Phi \leq 0.1$	Ignore													
$0.1 < \Phi \leq 0.25$	3 (Distance>5mm)													
$0.25 < \Phi$	Not allowed													
8.3.3.2	Linear defect Black/white line Black/white scratch	<table border="1"> <thead> <tr> <th>Length(mm)</th> <th>Width (mm)</th> <th>Acceptable Q'ty</th> </tr> </thead> <tbody> <tr> <td></td> <td>$W \leq 0.03$</td> <td>Ignore</td> </tr> <tr> <td>$L \leq 5.0$</td> <td>$0.03 < W \leq 0.07$</td> <td>3</td> </tr> <tr> <td></td> <td>$0.07 < W$</td> <td>Follow 8.3.3.1</td> </tr> </tbody> </table>	Length(mm)	Width (mm)	Acceptable Q'ty		$W \leq 0.03$	Ignore	$L \leq 5.0$	$0.03 < W \leq 0.07$	3		$0.07 < W$	Follow 8.3.3.1
Length(mm)	Width (mm)	Acceptable Q'ty												
	$W \leq 0.03$	Ignore												
$L \leq 5.0$	$0.03 < W \leq 0.07$	3												
	$0.07 < W$	Follow 8.3.3.1												
8.3.3.3	Polarizer Bubbles Dent on polarizer	<table border="1"> <thead> <tr> <th>Diameter (mm)</th> <th>Acceptable Q'ty</th> </tr> </thead> <tbody> <tr> <td>$\Phi \leq 0.2$</td> <td>Ignore</td> </tr> <tr> <td>$0.2 < \Phi \leq 0.5$</td> <td>2 (Distance>5mm)</td> </tr> <tr> <td>$0.5 < \Phi$</td> <td>Not allowed</td> </tr> </tbody> </table>	Diameter (mm)	Acceptable Q'ty	$\Phi \leq 0.2$	Ignore	$0.2 < \Phi \leq 0.5$	2 (Distance>5mm)	$0.5 < \Phi$	Not allowed				
Diameter (mm)	Acceptable Q'ty													
$\Phi \leq 0.2$	Ignore													
$0.2 < \Phi \leq 0.5$	2 (Distance>5mm)													
$0.5 < \Phi$	Not allowed													

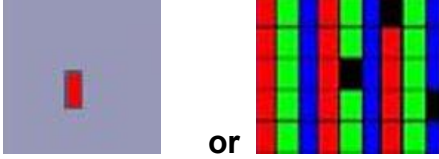
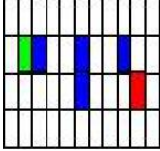
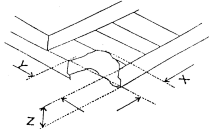
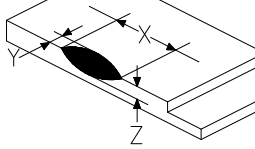
<p>8.3.3.4</p>	<p>Electrical Defect Dot</p>	<p>Bright dot and Dark dot definition:</p>  <p>or</p>  <p>(Two adjacent dot)</p> <p>Inspection pattern: black, white, red, green, and blue screen.</p> <table border="1" data-bbox="730 730 1441 913"> <thead> <tr> <th>Items</th> <th>Acceptable Q'ty</th> </tr> </thead> <tbody> <tr> <td>Bright dot</td> <td>$N \leq 4$ (Distance >5mm)</td> </tr> <tr> <td>Dark dot</td> <td>$N \leq 4$ (Distance >5mm)</td> </tr> </tbody> </table>	Items	Acceptable Q'ty	Bright dot	$N \leq 4$ (Distance >5mm)	Dark dot	$N \leq 4$ (Distance >5mm)
Items	Acceptable Q'ty							
Bright dot	$N \leq 4$ (Distance >5mm)							
Dark dot	$N \leq 4$ (Distance >5mm)							
<p>8.3.3.5</p>	<p>Glass Defect- Corner chipping</p>	 <table border="1" data-bbox="730 1104 1441 1375"> <thead> <tr> <th>Size(mm)</th> <th>Judgement</th> </tr> </thead> <tbody> <tr> <td> $X \leq 3\text{mm}$, $Y \leq S$, $Z \leq T$ (S= ITO length, T=Single glass thickness) </td> <td>Accept</td> </tr> </tbody> </table>	Size(mm)	Judgement	$X \leq 3\text{mm}$, $Y \leq S$, $Z \leq T$ (S= ITO length, T=Single glass thickness)	Accept		
Size(mm)	Judgement							
$X \leq 3\text{mm}$, $Y \leq S$, $Z \leq T$ (S= ITO length, T=Single glass thickness)	Accept							
<p>8.3.3.6</p>	<p>Glass Defect- Side fragment</p>	 <table border="1" data-bbox="730 1574 1441 1787"> <thead> <tr> <th>Size(mm)</th> <th>Judgement</th> </tr> </thead> <tbody> <tr> <td> $X \leq 2 \text{ mm}$, $Y \leq \text{border edge}$ $Z \leq T$ (T= single glass thickness) </td> <td>Accept</td> </tr> </tbody> </table>	Size(mm)	Judgement	$X \leq 2 \text{ mm}$, $Y \leq \text{border edge}$ $Z \leq T$ (T= single glass thickness)	Accept		
Size(mm)	Judgement							
$X \leq 2 \text{ mm}$, $Y \leq \text{border edge}$ $Z \leq T$ (T= single glass thickness)	Accept							

8.3.4 Minor defect (Touch Panel)

Item No.	Inspection content	Judgement
----------	--------------------	-----------

File NO.

REV

A/01

<http://www.yes-display.com>

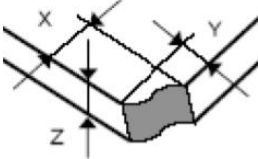
8.3.4.1	Scratch, dust, particles, foreign materials in "linear type"	Size (mm)	Acceptable Q'ty
		$W \leq 0.05\text{mm}, L \leq 10\text{mm}$	Ignore
		$0.05\text{mm} < W \leq 0.07\text{mm}, L \leq 10\text{mm}$	3
		$W > 0.07\text{mm}$	Reject
8.3.4.2	Scratch, dust, particles, foreign materials in "round type"	Diameter (mm)	Acceptable Q'ty
		$\Phi \leq 0.25\text{mm}$	Ignore
		$0.25\text{mm} < \Phi \leq 0.35\text{mm}$	5
		$\Phi > 0.35\text{mm}$	Reject
8.3.4.3	Air bubbles	Diameter (mm)	Acceptable Q'ty
		$\Phi \leq 0.2\text{mm}$	Ignore
		$0.2\text{mm} < \Phi \leq 0.5\text{mm}$	3
		$\Phi > 0.5\text{mm}$	Reject
8.3.4.5	Scratch on printing area	Size (mm)	Acceptable Q'ty
		$W \leq 0.03\text{mm}, L \leq 5\text{mm}$	Ignore
		$0.03\text{mm} < W \leq 0.05\text{mm}, L \leq 5\text{mm}$	3
		$W > 0.05\text{mm}$ or $L > 5\text{mm}$	Reject
8.3.4.6	Corner chipping		
		Size(mm)	Judgement
		$X \leq 2\text{mm}, Y \leq 2\text{mm}$ $Z < 1/2T$ (T= single glass thickness)	Accept

File NO.

REV

A/01

<http://www.yes-display.com>

8.3.4.7

Edge chipping

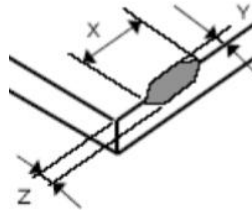

Size(mm)	Judgement
$X \leq 3 \text{ mm}$, $Y \leq 3 \text{ mm}$ $Z \leq 1/2 T$ (T= single glass thickness)	Accept

深圳市亿显国际科技有限公司 ShenZhen Yes-Display International Technology CO.,LTD.			2.9 寸液晶显示屏 2.9 Inch LCD Display Screen	
File NO.		REV	A/01	http://www.yes-display.com

9. Reliability Test Conditions and Methods

9.1 Reliability Test Conditions and Methods:

NO.	TEST ITEMS	TEST CONDITION	INSPECTION AFTER TEST
①	High Temperature Storage	80°C±2°C×96Hours	Inspection after 2~4hours storage at room temperature, the samples should be free from defects: 1, Air bubble in the LCD. 2, Seal leak. 3, Non-display. 4, Missing segments. 5, Glass crack. 6, Current IDD is twice higher than initial value. 7, The surface shall be free from damage. 8, The electric characteristic requirements shall be satisfied.
②	Low Temperature Storage	-30°C±2°C×96Hours	
③	High Temperature Operating	70°C±2°C×96Hours	
④	Low Temperature Operating	-20°C±2°C×96Hours	
⑤	Temperature Cycle(Storage)	-20°C ↔ 25°C ↔ 70°C (30min) ← (5min) → (30min) 1cycle Total 10cycle	
⑥	Damp Proof Test (Storage)	50°C±5°C×90%RH×96Hours	
⑦	Vibration Test	Frequency:10Hz~55Hz~10Hz Amplitude:1.5MM X,Y,Z direction for total 3hours (packing condition test will be tested by a carton)	
⑧	Drooping Test	Drop to the ground from 1M height one time every side of carton. (packing condition test will be tested by a carton)	
⑨	ESD Test	Voltage:±8KV,R:330Ω,C:150PF,Air Mode,10times	

深圳市亿显国际科技有限公司 ShenZhen Yes-Display International Technology CO.,LTD.			2.9 寸液晶显示屏 2.9 Inch LCD Display Screen	
File NO.		REV	A/01	http://www.yes-display.com

REMARK:

- 1, The Test samples should be applied to only one test item.
- 2, Sample side for each test item is 5~10pcs.
- 3, For Damp Proof Test, Pure water(Resistance > 10MΩ) should be used.
- 4, In case of malfunction defect caused by ESD damage, if it would be recovered to normal state after resetting, it would be judge as a good part.
- 5, EL evaluation should be accepted from reliability test with humidity and temperature: Some defects such as black spot/blemish can happen by natural chemical reaction with humidity and Fluorescence EL has.
- 6, Failure Judgment Criterion: Basic Specification Electrical Characteristic, Mechanical Characteristic, Optical Characteristic.

深圳市亿显国际科技有限公司 ShenZhen Yes-Display International Technology CO.,LTD.			2.9 寸液晶显示屏 2.9 Inch LCD Display Screen	
File NO.		REV	A/01	http://www.yes-display.com

10. Cautions and Handling Precautions

10.1 Mounting method

The LCD panel of TFT module consists of two thin glass plates with polarizes which easily be damaged. And since the module in so constructed as to be fixed by utilizing fitting holes in the printed circuit board.

Extreme care should be needed when handling the LCD modules.

10.2 Caution of LCD handling and cleaning

When cleaning the display surface, Use soft cloth with solvent

[Recommended below] and wipe lightly

- Isopropyl alcohol
- Ethyl alcohol

Do not wipe the display surface with dry or hard materials that will damage the polarizer surface.

Do not use the following solvent:

- Water
- Aromatics

Do not wipe ITO pad area with the dry or hard materials that will damage the ITO patterns

Do not use the following solvent on the pad or prevent it from being contaminated:

- Soldering flux
- Chlorine (Cl) , Sulfur (S)

If goods were sent without being silicon coated on the pad, ITO patterns could be damaged due to the corrosion as time goes on.

If ITO corrosion happen by miss-handling or using some materials such as Chlorine (Cl), Sulfur (S) from customer, Responsibility is on customer.

10.3 Caution against static charge

The LCD module use C-MOS LSI drivers, so we recommended that you:

Connect any unused input terminal to power or ground, do not input any signals before power is turned on, and ground your body, work/assembly areas, and assembly equipment to protect against static electricity.

深圳市亿显国际科技有限公司 ShenZhen Yes-Display International Technology CO.,LTD.			2.9 寸液晶显示屏 2.9 Inch LCD Display Screen	
File NO.		REV	A/01	http://www.yes-display.com

10.4 packing

- Module employs LCD elements and must be treated as such.
- Avoid intense shock and falls from a height.
- To prevent modules from degradation, do not operate or store them exposed direct to sunshine or high temperature/humidity

10.5 Caution for operation

- It is an indispensable condition to drive LCD's within the specified voltage limit since the higher voltage then the limit cause the shorter LCD life.
- An electrochemical reaction due to direct current causes LCD's undesirable deterioration, so that the use of direct current drive should be avoided.
- Response time will be extremely delayed at lower temperature then the operating temperature range and on the other hand at higher temperature LCD's how dark color in them. However those phenomena do not mean malfunction or out of order with LCD's, which will come back in the specified operation temperature.
- If the display area is pushed hard during operation, some font will be abnormally displayed but it resumes normal condition after turning off once.
- Slight dew depositing on terminals is a cause for electro-chemical reaction resulting in terminal open circuit.

Usage under the maximum operating temperature, 50%Rh or less is required.

10.6 storing

In the case of storing for a long period of time for instance, for years for the purpose or replacement use, the following ways are recommended.

- Storage in a polyethylene bag with the opening sealed so as not to enter fresh air outside in it. And with no desiccant.
- Placing in a dark place where neither exposure to direct sunlight nor light's keeping the storage temperature range.
- Storing with no touch on polarizer surface by the anything else.

[It is recommended to store them as they have been contained in the inner container at the time of delivery from us

10.7 Safety

- It is recommendable to crash damaged or unnecessary LCD's into pieces and wash off liquid crystal by either of solvents such as acetone and ethanol, which should be burned up later.

深圳市亿显国际科技有限公司 ShenZhen Yes-Display International Technology CO.,LTD.			2.9 寸液晶显示屏 2.9 Inch LCD Display Screen	
File NO.		REV	A/01	http://www.yes-display.com

- When any liquid leaked out of a damaged glass cell comes in contact with your hands, please wash it off well with soap and water

11. Packing Method

11.1 Method

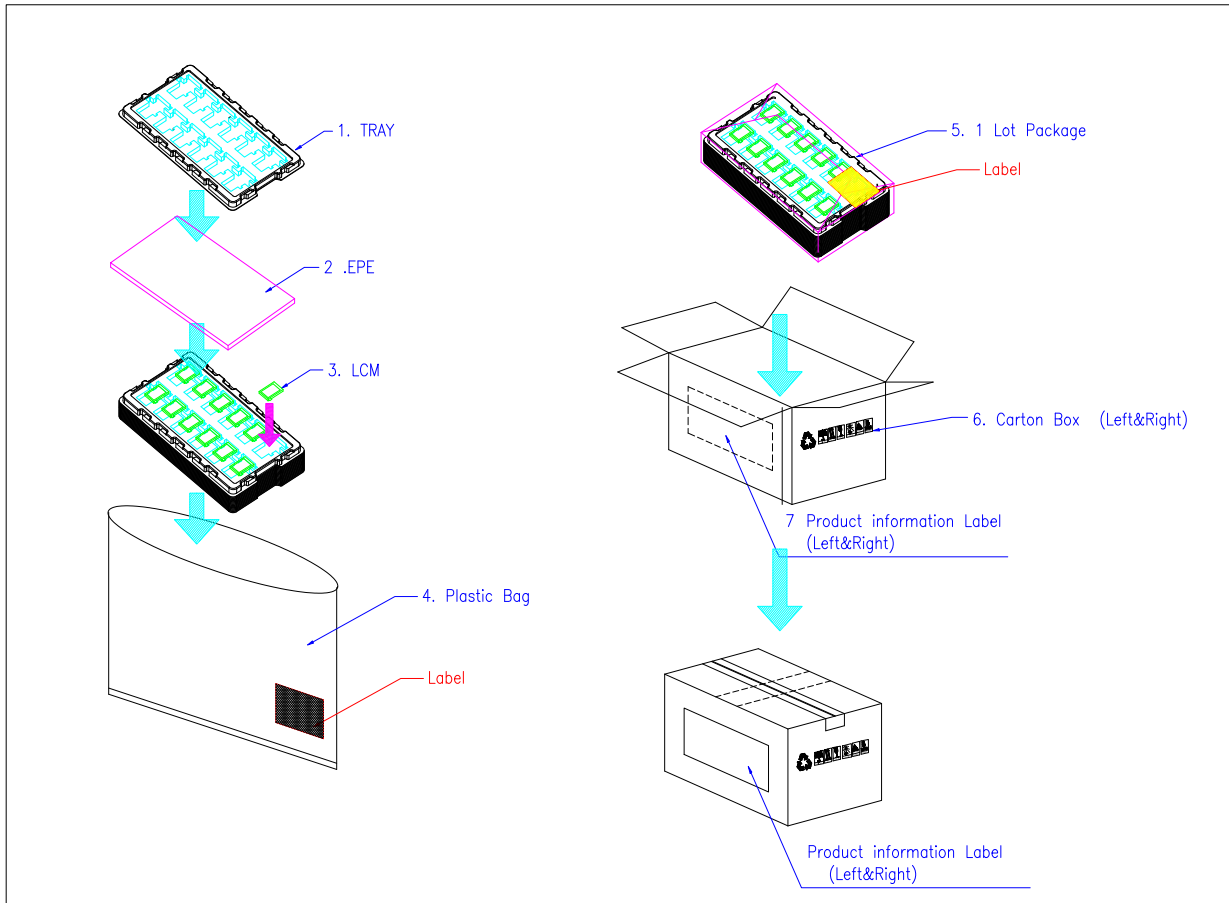

11.2 Packing Label

TBD